



PRECISION LATHE

SSM-1340BV

Accessories & Features

Standard Accessories

1. 7" 3-Jaw Chuck (177mm)
2. 8" 4-Jaw Chuck (203mm)
3. Steady Rest & Follow Rest
4. 4-Position Tool Post
5. Coolant System
6. Full-Length Splash Guard
7. Worklight
8. Chuck Cover
9. Thread Chasing Dial

Optional Accessories

1. Acu-Rite 200S DRO
(2-axis, x=0.0001" (0.00254mm) / z=0.0002" (0.00508 mm) res)*
2. Royal Spindle Type Live Center
3. BTC 3-Jaw Chuck with back plate
4. Taper Turning Attachment
5. Aloris CXA #3-BS (tool post plus 4 holders)
6. 5C Lever Style Collet Closer
7. 5C Front Mount Hand Wheel Style Collet Closer

Machine Features

- 3 hp Main Spindle Motor (2.23kw)
- Digital RPM Display for Hi/Low Gear Speed Ranges
- Capable of being run on Single Phase or 3 Phase power
- Hardened & Ground Gears and Bedways
- Jog Button
- Cast Iron Machine Bedways
- Removable Chip Pan
- Foot brake and T-Slot compound
- Inch/Metric Ruler on Tailstock Quill



Specifications

Model	SSM-1340BV
Swing Over Bed	13" (330mm)
Swing Over Cross Slide	8-1/4" (210mm)
Swing Over Gap	18-1/2" (470mm)
Width of Bed	7-1/2" (190mm)
Distance Between Centers	40" (1016mm)
Cross Slide Travel	6-3/4" (172mm)
Top Slide Travel	3-1/2" (90mm)
Spindle Bore	1.5" (38mm)
Spindle Speeds	2
Spindle Speed Range	40-365 & 218-2000 rpm
Through Hole Diameter	1-9/16" (40mm)
Spindle Nose	ASA D1-4 Camlock
Spindle Bore Taper	MT#5
Thread – Standard (Whit-worth)	34 (2-56) TPI
Thread – Metric Pitch	33 (0.5-12) mm
Longitudinal Feed	0.0016"–0.046" (0.04064-0.11684 mm)
Cross Feed	0.0005"–0.015" (0.0127-0.381 mm)
Lead Screw Diameter	7/8" (22mm)
Thread Pitch	8 tpi (203 mm)
Quill Travel	4" (101mm)
Quill Diameter	1-9/16" (40mm)
Quill Bore Taper	MT#3
Main Motor	3 hp (2.23kw)
Coolant Pump Motor	1/8 hp (.125 kw)
Machine Dimension	74" x 28" x 54" (1879 x 711 x 1371 mm)
Packing Dimension	77" x 30" x 60" (1955 x 762 x 1524 mm)
Machine Weight	1320 lbs (598kg)
Packing Weight	1584 lbs (718kg)

The above specifications are for reference only, we reserve the right to alter them without further notice.

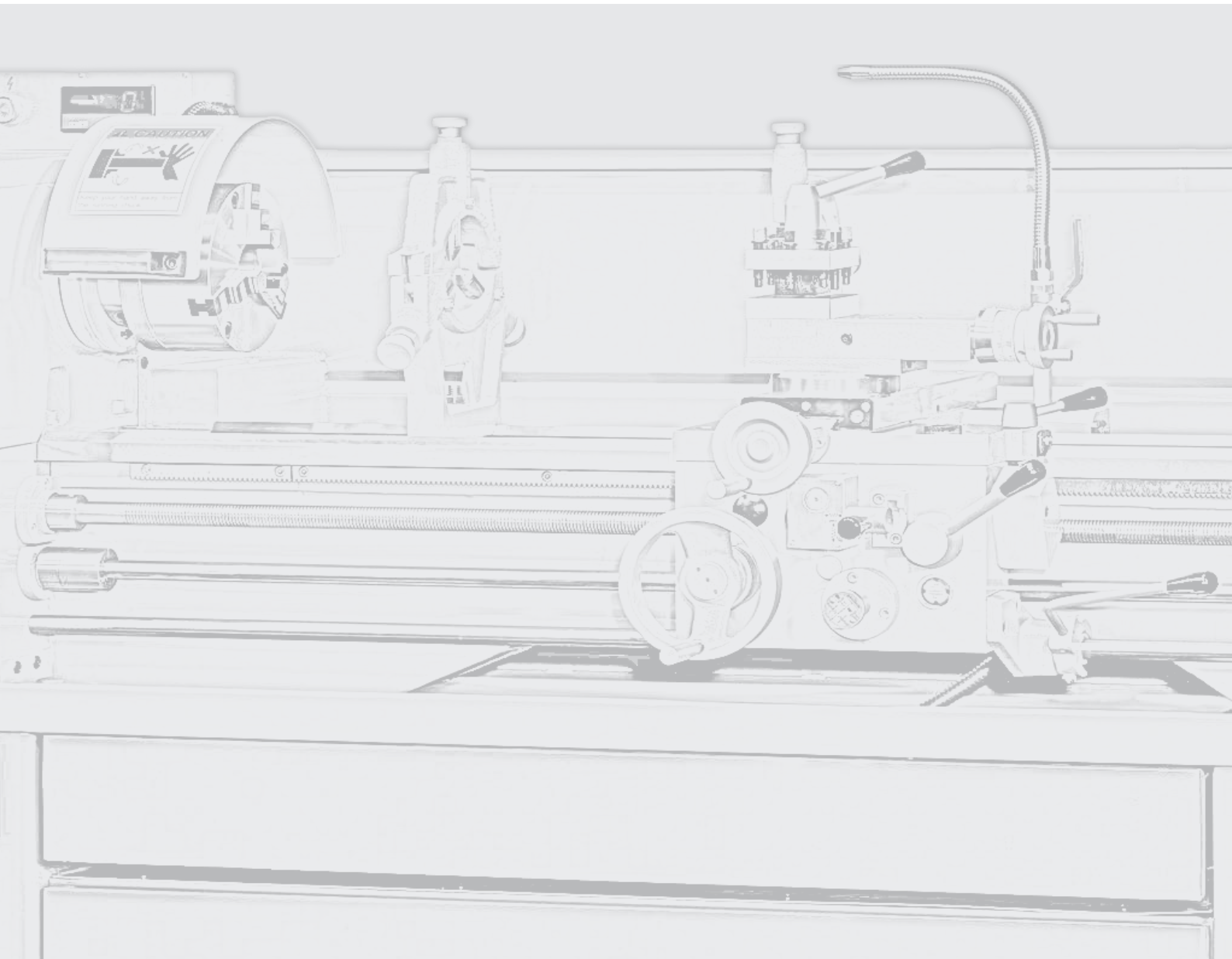

Kent Industrial USA, INC

1231 Edinger Avenue
Tustin, CA 92780 USA
Phone: +1.714.258.8526
E-mail: info@kentusa.com
www.kentusa.com