

TECHNOLOGY

CREATIVITY

RELIABILITY

SMOOTH YOUR WAY TO SECESS

**KENT
USA**

Precision Surface Grinders

618M

816M/MR

1020AHD/SD

1230AHD/SD

1640AHD/SD

2040AHD/SD

S2460AHD/SD

Precision Surface

Manufactured to exact tolerance:

Parallelism:

**Longitudinal Axis
0.0001"/12"**

**Cross Axis
0.0002"/12"**

**Vertical Axis
0.0002"/12"**

Squareness:

**X-Y-Z Axes
0.0008"/12"**

**Flatness:
0.0008"/12"**

**Spindle Runout:
0.0008"/12"**

AUTOMATIC SURFACE GRINDER

"The rapid elevation motor helps me set up my jobs quickly and effortlessly. A real time saver."

"The centralized automatic lubrication system makes my maintenance work a breeze."

"Excellent tech-support. It's great talking to people who really know their stuff."



"Simple intuitive controls keep me on schedule making parts."

"Dependable. Keeps working day in and day out."

SGS-1230AHD

Grinder

....Knowledge Driven Innovations
Since 1979

SADDLE TRAVERSE



SGS-1020AHD



SGS-1640AHD

MANUAL HANDFEED GRINDER



CGS-618M



SGS-816M/MR



*"Micro-downfeed
dial and rapid elevation
motor standard on 816MR
models."*

Precision Surface

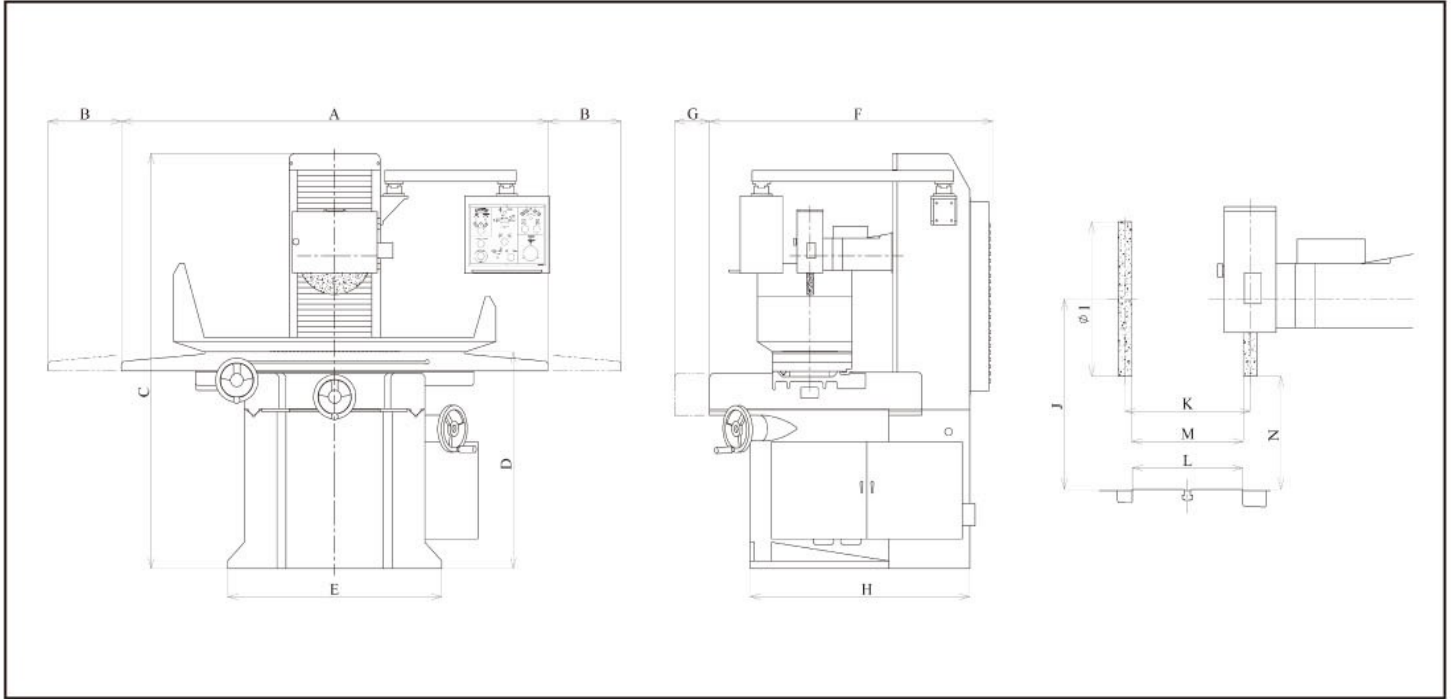

INCH (MM)

	SGS-816 M/MR	SGS-1020 AHD/SD	SGS-1230 AHD/SD	SGS-1640 AHD/SD
A	45.7" (1160)	65.4" (1660)	84.6" (2150)	114.2" (2900)
B	8.5" (215)	11.1" (282)	16.5" (420)	22.8" (580)
C	67.7" (1720)	68.5" (1740)	74" (1880)	78.7" (2000)
D	36.3" (922)	35.3" (897)	36.1" (917)	37.7" (957)
E	24.3" (616)	35" (890)	39.8" (1010)	41.5" (1055)
F	35.4" (900)	40.2" (1020)	46.7" (1185)	63" (1600)
G	4.2" (107)	5.2" (132)	6.5" (166)	8.9" (225)
H	29.5" (750)	34.3" (870)	40.7" (1035)	56.1" (1425)
I	8.1" (205)	8.1" (205)	14" (355)	14" (355)
J	18.1" (460)	19.7" (500)	23.6" (600)	24.4" (620)
K	8.4" (213)	10.4" (263)	13.1" (332)	17.7" (450)
L	6.3" (160)	9.1" (230)	10.2" (260)	15.7" (400)
M	8" (203)	10" (254)	12" (304)	16" (406)
N	14.2" (360)	15.7" (400)	16.5" (420)	17.3" (440)

*We follow a policy of continuous improvement of all our products, and reserve the right to change specifications, or design at any time without prior notice or obligation.

Grinder

.... Quality, Value & Service
Since 1979

AUTO DOWNFEED

Models 1020AHD - 1640AHD

- Elevation motor for quick and easy grinding wheel rapid positioning.
- Surface grinding and Slot/Plunge grinding modes selectable.
- Easy to use direct reading slip ring sets the total amount of material to grind, with no need to calculate the number of passes required.
- A separate dial sets the down feed amount per pass between 0 and 0.001" in 0.0001" increments, which can be changed on the fly to accommodate grinding conditions without affecting the total grinding amount set in the previous step.
- Machine will spark out continuously at the end of the auto grinding cycle.
- This easy and intuitive system provides both control and flexibility to the operator, enabling the work to be done precisely and efficiently.

SPINDLE

Specially designed, dynamically balanced cartridge type spindle is totally enclosed and grease lubricated for the life of the spindle. Two pairs of ABEC-7 super precision angular contact bearings are matched and preloaded to enhance maximum grinding accuracy and reliability.



CONTROL SYSTEM

Simple and logical layout of electrical and electronic components with color and number coded electrical wiring provides reliable operation and easy troubleshooting or service. Control circuit operates on 24v AC for the safety of the operator.



ACCESSORIES

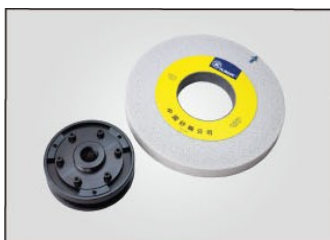

Grinding Wheel &
Wheel Flange



Hydraulic System



Wheel Balancing Base



Magnetic Separator &
Paper Filter Coolant
System



Wheel Balancing Arbor



Table Diamond Dresser
Base & Tip

Precision Surface

COLUMN TRAVERSE TYPE

20" x 40" through 34" x 120" Capacity

- Dynamically balanced precision spindle wiff 3 pairs of precision ABEC-7 (P4) angular contact ball bearings for extra heavy cut
- Rapid elevation mode for quicker set-ups
- Selectable surface and slot grinding modes
- Digital counter for setting number of auto downfeed passes and spark out passes (AHD Type)
- Ten choices of downfeed Increment settings from 0.0002" to 0.002" per pass [AHD Type]
- Automatic shut off of spindle and hydraulic system after completion of automatic downfeed cycle
- (AHDType)
- V and flat longitudinal ways lined with Turcite-B Teflon linings for the smoothest movement and longevity
- Double V crossfeed ways for extra rigidity and accuracy over time
- Column traverse design allows for easy access to table to ease loading and unloading of large work pieces

SGS-2040AHD/SD
SGS-2448AHD
SGS-2480AHD
SGS-3488AHD

SGS-S2460AHD/SD
SGS-2460AHD
SGS-3468AHD
SGS-34120AHD



SGS-2040AHD

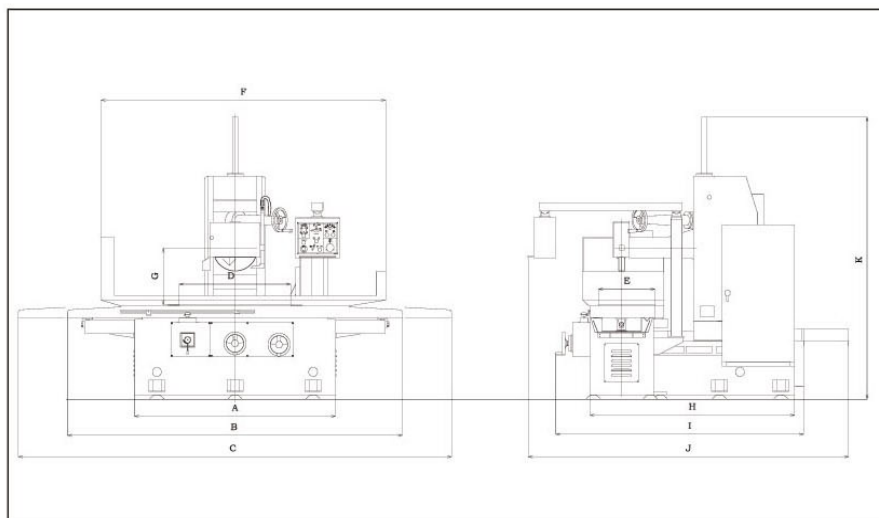

INCH (MM)

	SGS-2040 AHD/SD	SGS-2460 AHD/SD
A	70.8" (1800)	110.2" (2800)
B	118.1" (3000)	171.2" (4350)
C	163.7" (4160)	244" (6200)
D	41.7" (1060)	60" (1524)
E	20" (508)	23.9" (608)
F	100.3" (2550)	135.6" (3445)
G	23.6" (600)	23.6" (600)
H	72" (1830)	82.6" (2100)
I	87.4" (2220)	97.6" (2480)
J	109.4" (2780)	119.6" (3040)
K	95.2" (2420)	95.2" (2420)

*We follow a policy of continuous improvement of all our products, and reserve the right to change specifications, or design at any time without prior notice or obligation.

Grinder

.... Proven Reliability and Success
Since 1979

SD DOWNFEED MODEL FEATURES

- European CE certified electrics
- Proportional valve hydraulic system
- Proximity sensors for table reversal
- Table speed Infinitely variable from 3.3'/mlnute to 83'/minute
- Easy electronic setting of crossfeed reversal positions on the control panel
- Servo motor downfeed system with close loop feedback
- Intuitive setting of total stock removal amount on automatic downfeed cycle with rough and fine feed and sparkout cycles
- Selectable surface and slot grinding modes
- Manual pulse generator Z axis handwheel and digital display of Z axis position allow for quicker setup of repetitive cycles

SGS-1020SD SGS-1230SD
SGS-1640SD SGS-2040SD

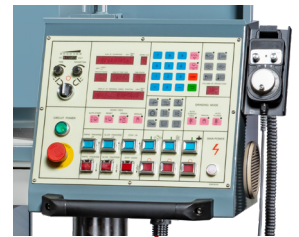

SGS-1020SD

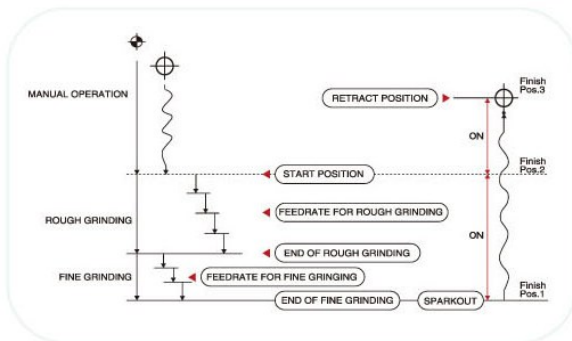

DOUBLE COLUMN BRIDGE TYPE

47" x 59" through 70" x 472" Capacity

- SGS-1512AHD
- SGS-2012AHD
- SGS-2512AHD
- SGS-3012AHD
- SGS-4018AHD
- SGS-5018AHD
- SGS-6018AHD
- SGS-7018AHD

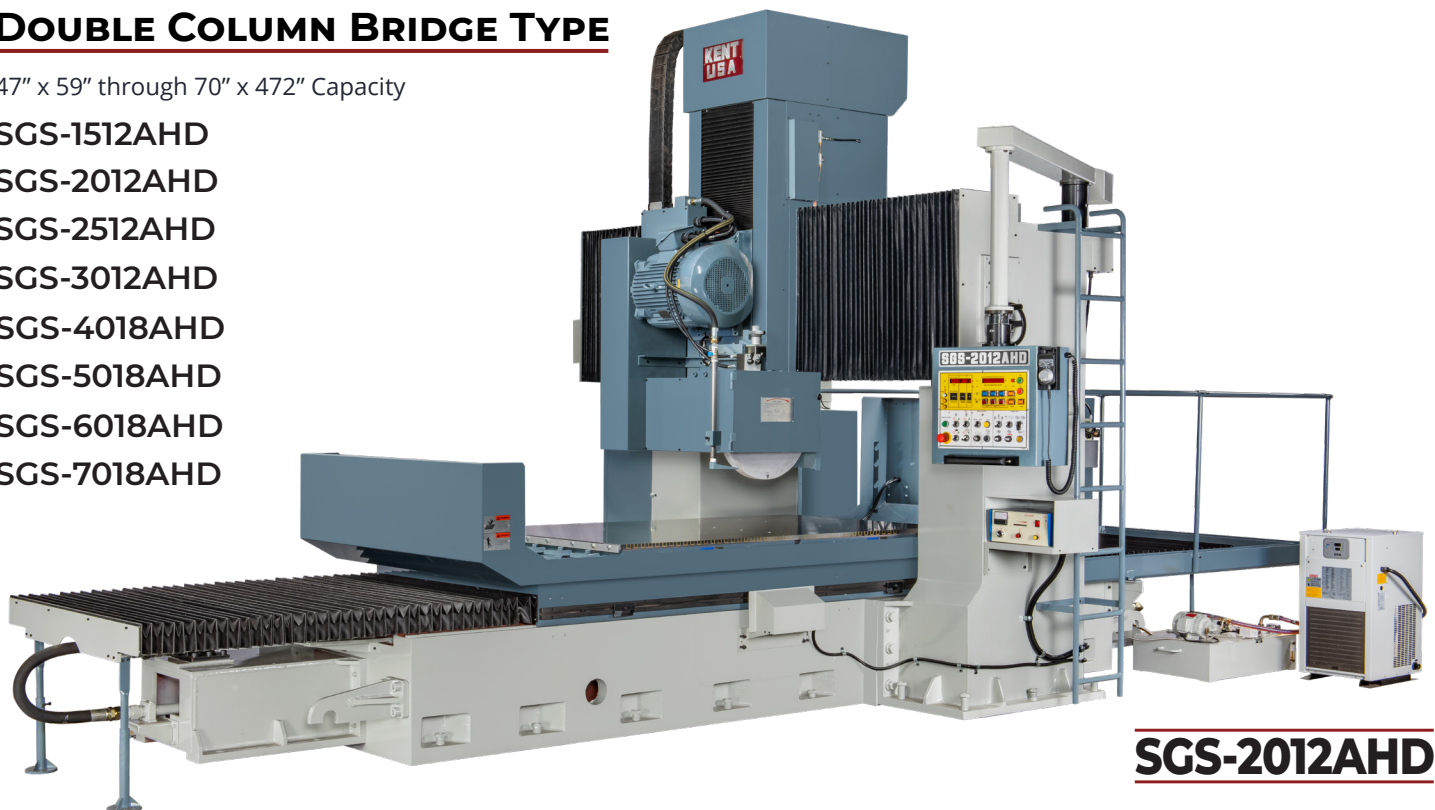

SGS-2012AHD

Specifications & Accessories

INCH

Model	CGS-618	SGG-816 M/MR	SGS-1020 AHD/SD	SGS-1230 AHD	SGS-1640 AHD/SD	SGS-2040 AHD/SD	SGS-S2460 AHD/SD
Working Capacity	6" x 18"	8" x 16"	10" x 20"	12" x 30"	16" x 40"	20" x 40"	23.5" x 59"
Table Travel	19"	17"	22.2"	33"	45.6"	45.6"	65"
Saddle Travel	6.69"	8.25"	10.3"	13"	17.7"	21.6"	25.6"
T-Slot	1 x 9/16"	1 x 9/16"	1 x 9/16"	1 x 9/16"	1 x 9/16"	3 x 9/16"	3 x 9/16"
Spindle Motor	3 HP	2 HP	2 HP	5 HP	7.5 HP	10 HP	10 HP
Spindle Speed	3450 RPM	3450 RPM	3500 RPM	1750 RPM	1750 RPM	1750 RPM	1750 RPM
Grinding Wheel	8" x 1/2" x 1-1/4"	8" x 1/2" x 1-1/4"	8" x 1/2" x 1-1/4"	14" x 1-1/4" x 5"	14" x 2" x 5"	16" x 2" x 5"	16" x 2" x 5"
Vertical Graduation	0.0002"	0.00025" / 0.00005"	0.0005"	0.0005"	0.00025"	0.0001"	0.0001"
Vertical Revolution	0.050"	0.050"	0.100"	0.100"	0.050"	0.020"	0.020"
Spindle to Table	18"	18"	19.6"	23.6"	24.4"	0.0002" 10 Steps	0.0001" to 0.0333" Per Pass
Auto Downfeed Increment	--	--	0.0001" 10 Steps	0.0001" 10 Steps	0.0001" 10 Steps	23.6"	23"
Net Weight	1600 lbs	1540 LBS	2970 LBS	4290 LBS	6600 LBS	9900 LBS	13200 LBS
Gross Weight	1800 lbs	1860 LBS	3520 LBS	4950 LBS	7480 LBS	11000 LBS	15400 LBS

*We follow a policy of continuous improvement of all our products, and reserve the right to change specifications, or design at any time without prior notice or obligation.

Standard Accessories

1. Grinding Wheel
2. Permanent Magnetic Chuck
3. Wheel Flange & Wheel flange Extractor
4. Balancing Base & Arbor
5. Table Diamond Dresser Base
6. Leveling bolts & Pads
7. Toolbox with standard tools
8. Work Light

Optional Accessories

1. Electric Magnetic Chuck
2. Control Flood Coolant System
3. Dust-Suction Coolant System
4. Paper filter & Magnetic Separator Coolant Unit
5. Manual Overhead Parallel Dresser
6. Digital Readout System



KENT INDUSTRIAL USA INC.

1231 Edinger Avenue Tustin, CA 92780

Phone: +1(714)-258-8526

Email: info@kentusa.com

www.kentusa.com | www.kentcnc.com